

BUS STOP IMPROVEMENT PLAN

Preliminary Findings & Recommendations

April 6, 2022

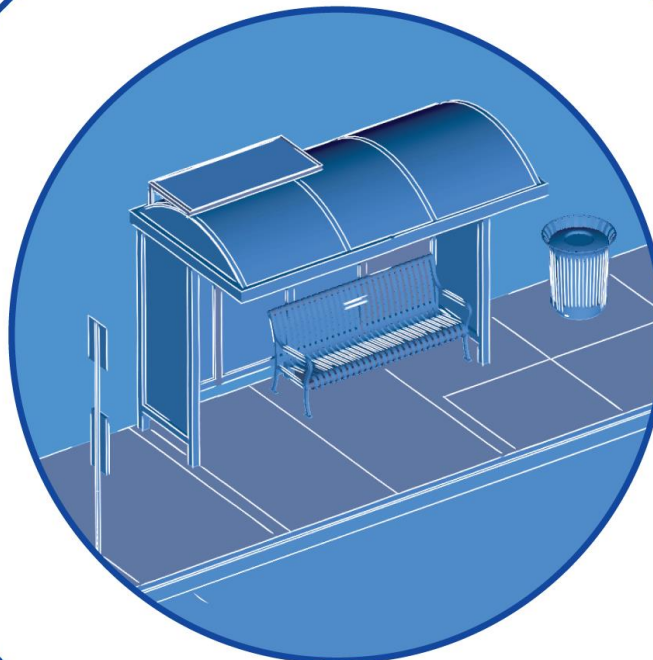

Background



2019 Bus Stop Guidelines

2021 Bus Stop Inventory

2022 Bus Stop Improvement Plan

Table 5 Bus Stop Classification and Recommended Amenities

Amenities	Class I	Class II	Class III
	21 + daily boardings	10 to 20 daily boardings	< 10 daily boardings
Pole with Bus Stop Sign and Route Number	Required at all stops		
Red Curb or No Parking Restriction	Required at all stops		
Lighting	Provide		
Seating	Provide*	Provide	Recommended
Waste Receptacles	Provide	Provide	Optional
Shelter	Provide*	Recommended	Optional
Bike Rack	Optional	Optional	Optional

*Stops with 50 or more daily boardings may require more than one shelter and bench.

Outreach

What We Heard:

- More Seating
- Better Lighting
- Stop Cleanliness
- Parking Restrictions

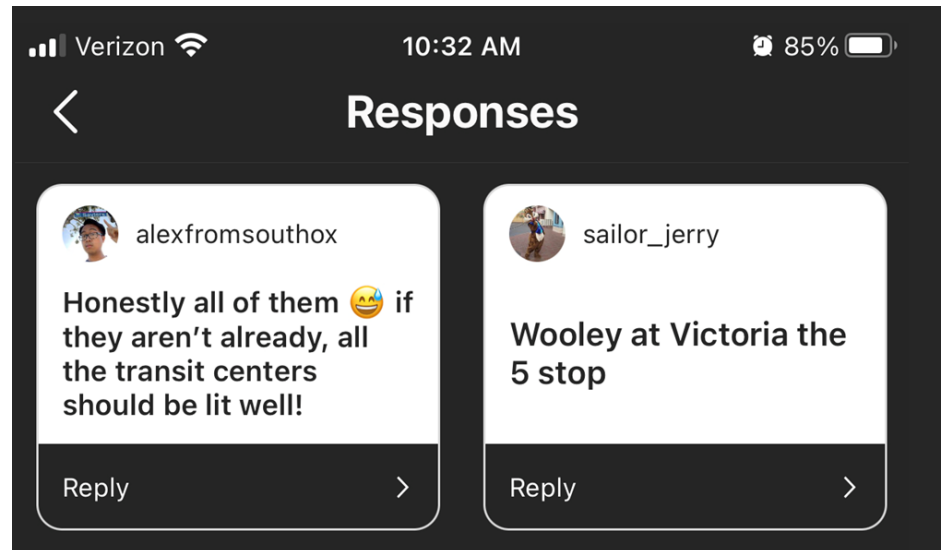

Prioritization & Equity

Prioritization Methodology

- Ridership
- Priority Populations
 - Disadvantaged Communities
 - Low Income Communities
- Equity Weighted Utilization Score



Improvement Area: Amenity Maintenance

- 20-year useful life
- Replace 5% of amenities annually
-OR-
Approximately 8 shelters
and 25 benches annually



Improvement Area: New Amenities



37 BENCHES



40 SHELTERS



68 LIGHTING
IMPROVEMENTS

Improvement Area: Safety & Accessibility

- 38 ADA landings
- 45 Accessible pathways
- 59 Crosswalks

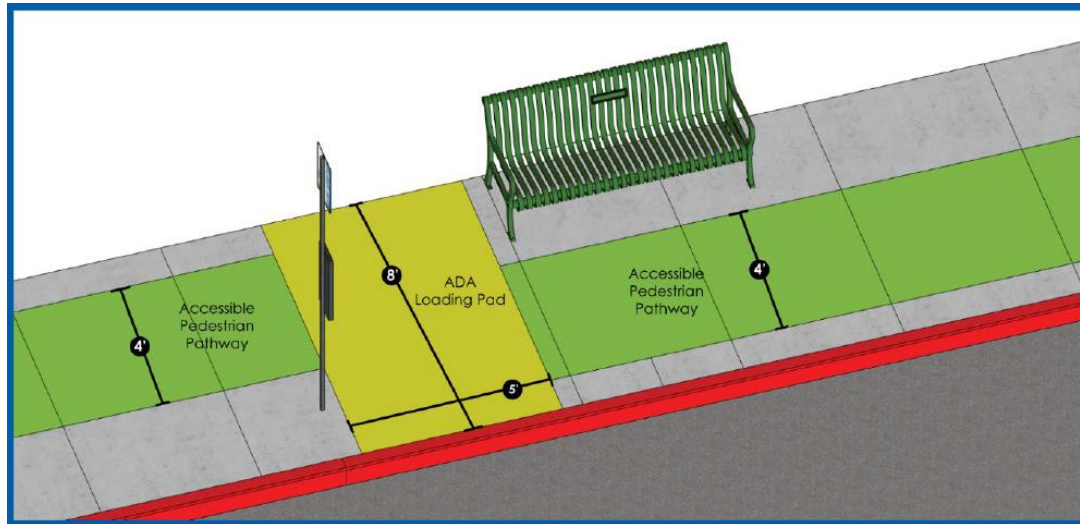

Improvement Area: Operational

- 5 Stop Balancing corridors
- 5 new bidirectional stops

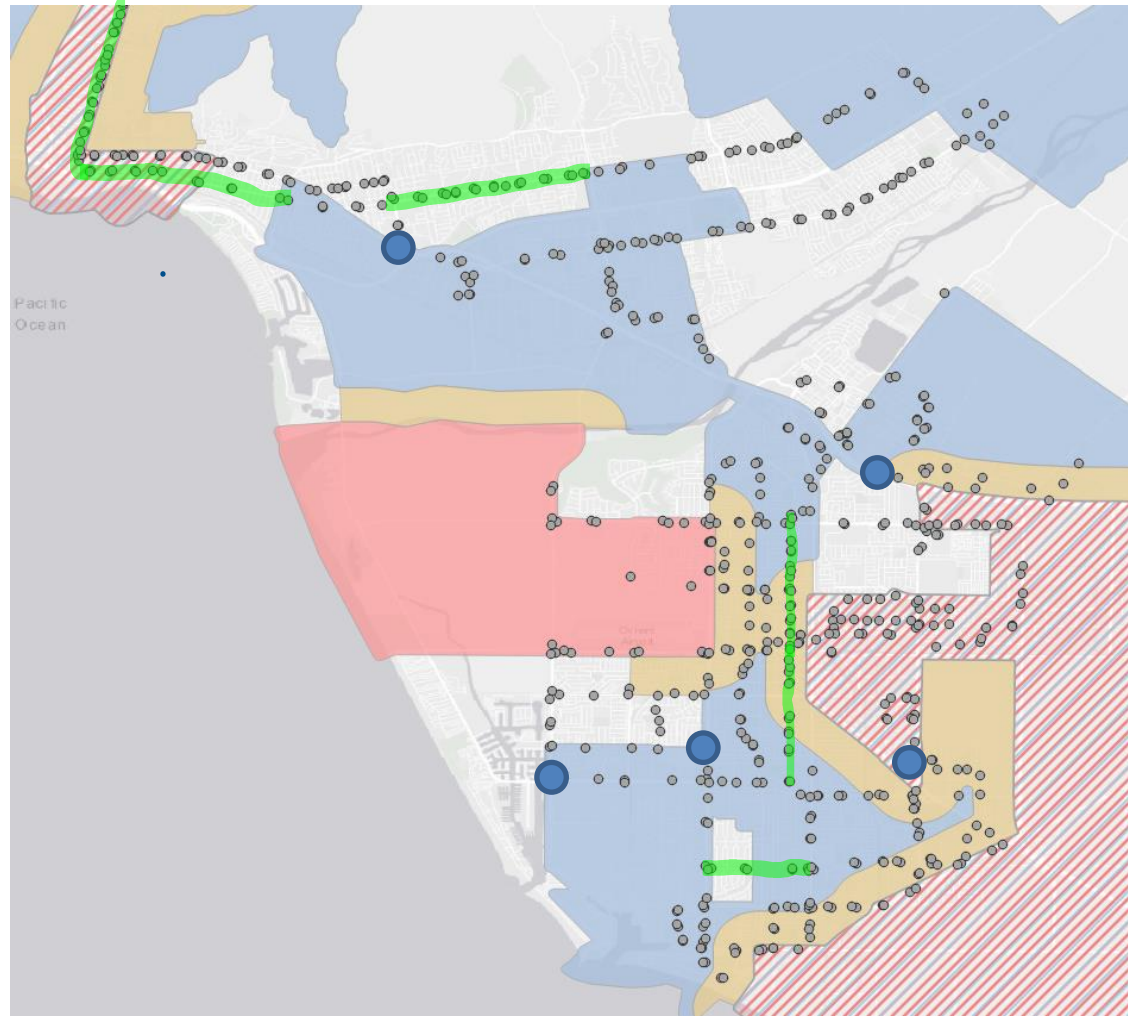

Questions?

